

Explosion protected switchgear



GHG 981 / GHG 982 Ex Safety switch for zone 22

GRP and Stainless steel enclosures for harsh environments



5.2

GHG 981... / GHG 982... Ex-Safety Switches and Switch disconnecter for Zone 22

Rated current from 25 A - 700 A

Safety first

Occupational safety always has top priority! For this reason, whenever it is necessary to carry out maintenance, cleaning or repair work, it must be possible to isolate machines and installations from the electrical power supply in an absolutely safe and reliable way. Normally this is realised by switch-disconnectors (safety-switches) according to **IEC/EN 62626-1**.

The GHG 981 / GHG982 safety switches approved for use in zone 22 areas containing explosive dust fulfils all these requirements. With the built-in padlocking facilities, they can be used as a load break switch with full confidence they will provide the required safety and personnel protection.

In what applications is IEC 62626-1 compliance required?

This standard applies to various applications to provide isolation of electrical equipment, namely motor circuits. Switch-disconnectors used in these applications are commonly known as "safety switches", "repair and maintenance switches", or "isolators" and are placed in close proximity to the equipment. Position switches, inspection switches, and other switches are not covered by this standard.

For any application

GHG 981... / GHG982 series safety switches up to 700 A. meet the strict requirements of class I IEC/EN 62626-1.

Emergency stop versions according to EN 60204-1

Optional emergency stop versions to EN 60204-1 featuring a red handle with a yellow backplate are also available. The additional leading or lagging auxiliary contact guarantees double safety for extreme switching conditions. All switch versions feature an earth terminal.

Special features of the safety switches include designs for ease of installation and readily accessible connection terminals.

Safety switches rated 100 A and below are available in all 2 material types while those 160 A and above are built into enclosures made of steel or electro-polished stainless steel. These enclosures can be fitted with screw-on flanges.

Enclosed Switch-Disconnectors to provide isolation during repair and maintenance.

GHG 981 / GHG982 switches (25- 700 A) are now confirmed to comply with the new standard IEC 62626-1, requirements Class 1.

The new standard IEC 62626-1 defines the requirements for safety switches (switch-disconnectors) that are used to provide isolation of equipment during repair and maintenance.

These requirements go above and beyond those of IEC 60947-3, where no standard previously existed.

The standard divides products into two classifications: Class 0 for general use and Class 1 for harsh and rough/heavy duty conditions.

All products installed in ATEX/ IECEx hazardous areas should be rated for Class 1. Class 1 requirements include minimum ratings for mechanical strength, IP protection, tamper resistance, heat/vibration/corrosion resistance, switching capacity, and locking capability.

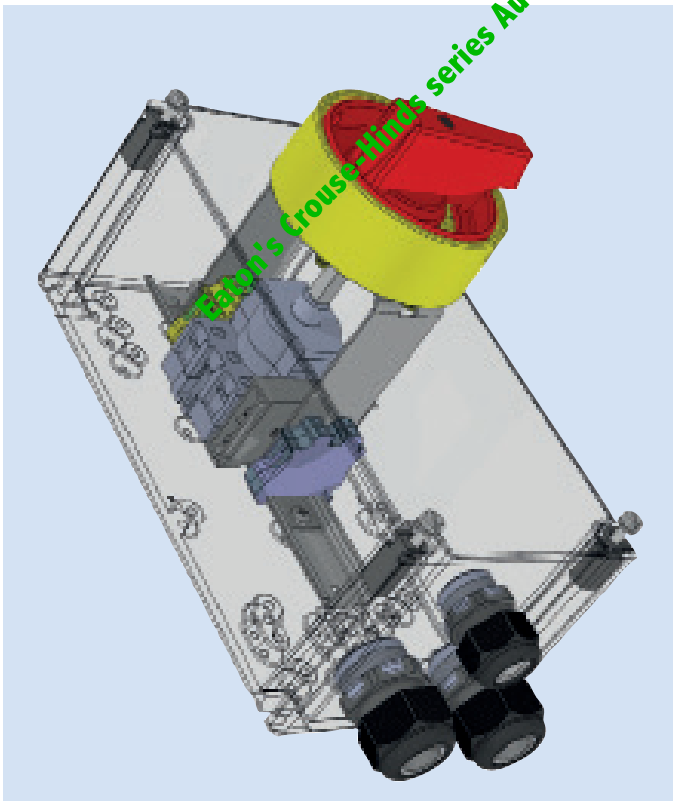

Features

- Approved for use in Zone 22 explosive dust atmospheres and for industrial applications
- For max. currents from 25A up to 700A
- AC3 and AC23 switching capacity
- Environmental protection to IP66
- Compliance with IEC / EN 62626-1
- Wide temperature range from -55 °C to +55 °C
- Can be locked in "OFF" position by max. 3 padlocks



The right size for every application

The switches are available in 3-pole, 4-pole, and 6-pole versions in sizes ranging from 25 A to 400 A. From the 500 A onwards switches are available in 3-pole or 4-pole versions.

All sizes from 25 A through 700 A feature full AC3 switching capacity for squirrel-cage motors during starting or while running per EN 60947-3 Appendix A. This is the most typical industrial application for motors.

Ready for harsh environments

The enclosures for our safety switches are designed with IP66 environmental protection and are available in glass-reinforced polyester (GRP), or electro-polished stainless steel. They are impact resistant and robust, corrosion-resistant, and are suitable for use in harsh industrial environments with extreme ambient temperature from -55 °C to +55 °C.

Lock-out/tag-out capability

All GHG981 and GHG982 safety switches come with built-in lock-out/tag-out capability and can be locked in the "OFF" position by means of max. 3 padlocks. While switched to the "OFF" position, the enclosure covers of safety switches cannot be opened without destroying the enclosure. This provides an extra level of safety as it prevents access to a switch locked in the "OFF" position, eliminating any risk of tampering with the switch position or electrical connections.

Electrical equipment for use in areas with combustible dust

Combustible dust can be ignited by electrical apparatus in various ways:

- by apparatus surface temperatures that are higher than the ignition or glow temperature of the respective dust. The temperature at which the dust ignites is dependent on the properties of the dust, on whether it is present in the form of a cloud or deposits, on the thickness of the layer and on the type of heat source
- by sparks at electrical parts such as switches, contacts, commutators, brushes or similar
- by the discharge of stored electrostatic energy
- by radiated energy (e.g. electromagnetic radiation)
- by magnetic impact or friction sparks or a rise in temperature originating from the apparatus.

To avoid ignition hazards, it is necessary that:

- the temperature of any surfaces on which dust deposits can form or that can come into contact with a cloud of dust are kept at a temperature that is lower than the limiting temperatures laid down in EN 50028-1-2
- all parts with electric sparks or with temperatures above the ignition or glow temperature of the dust are built into an enclosure that prevents the ingress of dust in a suitable manner, or
- the energy of the electric circuits is limited to such a degree, that sparks or temperature that could ignite combustible dust are avoided
- all other ignition sources are avoided.

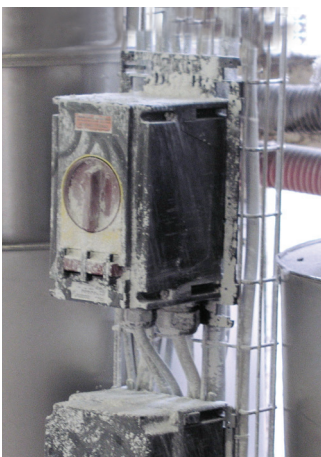

Eaton's Crouse-Hinds series Authorized distributor Kunshan Beiyuan electric co., ltd. / csr@ksbyel.com

GHG 981... / GHG 982... - Ex-safety switches zone 22



40 A sheet steel



40 A plastic



25 A stainless steel



25 A plastic

Technical Data

GHG 981... / GHG 982...

Marking to 2014/34/EU	II 3 D Ex tc IIIC T80°C Dc
Type Examination Certificate	CCH 15 ATEX 1001 / Safety Switch 25 A: CCH 22 ATEX 1005 X / Switch disconnecter 25 A: CCH 22 ATEX 1006 X
Permissible ambient temperature	-55 °C up to +40 °C/45 °C/50 °C/55 °C see instruction manual
IK-class according to EN 50102	IK 9 = ^ 10 J
Rated voltage	up to 690 V
Rated current	see ordering information
Frequency	50 - 60 Hz
Switch-disconnector for maintenance accd. to IEC 62262-1	Class 1 (25 A - 700 A)
Protection class	I and II
Degree of protection accd. to EN 60529	IP66
Auxiliary contact	1 x NO making - lagging, breaking - leading 1 x NC making - leading, breaking - lagging
Padlocking	can be logged in OFF position with 3 commercially available padlocks
Enclosure colour	Plastic = black /stainless steel 316L = electroplished

	GHG 982 (25 A)		GHG 981 (40 A)		GHG 981 (80 A)	
Back-up fuse	up to 415 V AC 50 A gG	up to 690 V AC 35 A gG	up to 415 V AC 80 A gG	up to 690 V AC 80 A gG	up to 415 V AC 100 A gG	up to 690 V AC 100 A gG
Rated making-/breaking capacity AC-3 accd. to EN 60947-3 Appendix A	25 A / 3/4 pole 23 A / 6 pole	14 A / 4 pole 11 A / 6 pole	40 A / 3 pole 40 A / 6 pole	22 A / 3 pole 17 A / 6 pole	71 A / 3 pole 55 A / 6 pole	23 A / 3 pole 17 A / 6 pole
Connecting terminals	2.5 mm ² - 6 mm ²		10 mm ² - 35 mm ²		25 mm ² - 70 mm ²	
	GHG 981 (100 A)		GHG 981 (160 A)		GHG 981 (250 A)	
Back-up fuse	up to 415 V AC 125 A gG	up to 690 V AC 125 A gG	up to 415 V AC 160 A gG	up to 690 V AC 160 A gG	up to 415 V AC 250 A gG	up to 690 V AC 250 A gG
Rated making-/breaking capacity AC-3 accd. to EN 60947-3 Appendix A	100 A	100 A	160 A	160 A	250 A	250 A
Connecting terminals	35 mm ² - 70 mm ²		70 mm ² / M8 x 25		120 mm ² / M8 x 25	
	GHG 981 (400 A)		GHG 981 (500 A)			
Back-up fuse	up to 415 V AC 400 A gG	up to 690 V AC 400 A gG	up to 415 V AC 630 A gG	up to 690 V AC 630 A gG	up to 415 V AC 800 A gG	up to 690 V AC 800 A gG
Rated making-/breaking capacity AC-3* accd. to EN 60947-3 Appendix A	400 A	400 A	500 A	500 A	700 A	700 A
Connecting terminals	1 x 240 mm ²		2 x 185 mm ² / M12 x 40		2 x 240mm ² / M12 x 40	

Eaton's Crouse-Hinds series Authorized distributor - Kunshan Beijuan electric co., ltd. / csr@ksbyel.com



25 A plastic



25 A sheet steel

Ordering details GHG 981 25 A - 100 A

Rated current	Poles	Enclosure material	Cable entry (metal thread)	Cable glands (plastic)	Enclosure sizes: GRP				Enclosure sizes: metall				Order No. ¹⁾
					Size 1	Size 2	Size 3	Size 4	Size 1	Size 2	Size 3	Size 4	
GHG 982 (25 A) Safety Switches													
25 A	3 pole	GRP		2xM32, 1xM25	X								GHG 982 1200 R3001
25 A	6 pole	GRP		4xM32, 1xM25	X								GHG 982 1200 R6001
25 A	3 pole	GRP + internal earth plate + stud	2xM25, 1xM20		X								GHG 982 1200 R3011
25 A	6 pole	GRP + internal earth plate + stud	4xM25, 1xM20		X								GHG 982 1200 R6012
25 A	3 pole	316L Stainless steel	2xM25, 1xM20										GHG 982 1200 R3021
25 A	6 pole	316L Stainless steel	4xM25, 1xM20						X				GHG 982 1200 R6021
GHG 982 (25 A) Emergency Stop													
25 A	3 pole	GRP		2xM32, 1xM25	X								GHG 982 1400 R3001
25 A	6 pole	GRP		4xM32, 1xM25	X								GHG 982 1400 R6001
25 A	3 pole	GRP + internal earth plate + stud	2xM25, 1xM20		X								GHG 982 1400 R3011
25 A	6 pole	GRP + internal earth plate + stud	4xM45, 1xM20		X								GHG 982 1400 R6012
25 A	3 pole	316L Stainless steel	2xM25, 1xM20						X				GHG 982 1400 R3021
25 A	6 pole	316L Stainless steel	4xM25, 1xM20						X				GHG 982 1400 R6021
GHG 982 (25 A) Switch-disconnector													
25 A	3 pole	GRP		2xM32, 1xM25	X								GHG 982 1100 R3001
25 A	4 pole	GRP		2xM32	X								GHG 982 1100 R4002
25 A	6 pole	GRP		4xM32, 1xM25	X								GHG 982 1100 R6001
25 A	3 pole	GRP + internal earth plate + stud	2xM25, 1xM25		X								GHG 982 1100 R3011
25 A	4 pole	GRP + internal earth plate + stud	2xM25		X								GHG 982 1100 R4012
25 A	6 pole	GRP + internal earth plate + stud	4xM25, 1xM20		X								GHG 982 1100 R6012
25 A	3 pole	316L Stainless steel	2xM25, 1xM20						X				GHG 982 1100 R3021
25 A	4 pole	316L Stainless steel	2xM25						X				GHG 982 1100 R4022
25 A	6 pole	316L Stainless steel	4xM25, 1xM20						X				GHG 982 1100 R6021

¹⁾ For an emergency stop switch (red handle, snow back plate), change the 3rd to last digit from R*2** (standard version) to R*3** (emergency stop)

Eaton's Crouse-Hinds series Authorized distributor: Kunshan Beiyuan Electric Co., Ltd. / csi@ksbyel.com

GHG 981... / GHG 982... - Ex-safety switches zone 22



160 A GRP



160 A stainless steel



250 A stainless steel

Ordering details GHG 981 40 A - 160 A

Rated current	Poles	Enclosure material	Cable entry (metal thread)	Cable glands (plastic)	Enclosure sizes: GRP				Enclosure sizes: metall				Order No. ¹⁾
					Size 1	Size 2	Size 3	Size 4	Size 1	Size 2	Size 3	Size 4	
GHG 981 (40 A)													
40 A	3 pole	GRP		2xM40, 1xM25				X					GHG 981 0048 R1221
40 A	4 pole	GRP		2xM40, 1xM25				X					GHG 981 0048 R1222
40 A	6 pole	GRP		4xM40, 1xM25				X					GHG 981 0048 R1223
40 A	3 pole	316L stainless steel	2xM40, 1xM25							X			GHG 981 0048 R1227
40 A	4 pole	316L stainless steel	2xM40, 1xM25								X		GHG 981 0048 R1228
40 A	6-pole	316L stainless steel	4xM40, 1xM25									X	GHG 981 0048 R1229
GHG 981 (80 A)													
80 A	3 pole	GRP		2xM50, 1xM25				X					GHG 981 0048 R1231
80 A	4 pole	GRP		2xM50, 1xM25				X					GHG 981 0048 R1232
80 A	6 pole	GRP		4xM50, 1xM25				X					GHG 981 0048 R1233
80 A	3 pole	316L stainless steel	2xM50, 1xM25								X		GHG 981 0048 R1237
80 A	4 pole	316L stainless steel	2xM50, 1xM25									X	GHG 981 0048 R1238
80 A	6-pole	316L stainless steel	4xM50, 1xM25									X	GHG 981 0048 R1239
GHG 981 (100 A)													
100 A	3 pole	GRP		2xM50, 1xM25				X					GHG 981 0048 R1241
100 A	4 pole	GRP		2xM63, 1xM25					X				GHG 981 0048 R1242
100 A	6 pole	GRP		4xM50, 1xM25					X				GHG 981 0048 R1243
100 A	3 pole	316L stainless steel	2xM50, 1xM25								X		GHG 981 0048 R1247
100 A	4 pole	316L stainless steel	2xM63, 1xM25									X	GHG 981 0048 R1248
100 A	6-pole	316L stainless steel	4xM50, 1xM25									X	GHG 981 0048 R1249
GHG 981 (160 A)													
160 A	3 pole	316L stainless steel	2xM50, 1xM25								X		GHG 981 0048 R1257
160 A	4 pole	316L stainless steel	2xM63, 1xM25									X	GHG 981 0048 R1258
160 A	6 pole	316L stainless steel	4xM50, 1xM25									X	GHG 981 0048 R1259

¹⁾ For an emergency stop switch (red handle/yellow back plate), change the 3rd to last digit from R*2** (standard version) to R*3** (emergency stop)

Eaton's Crouse-Hinds series Authorized distributor: Kunshan Beiyuan Electric Co., Ltd. / cst@ksbye.com



630 A stainless steel



700 A stainless steel

Ordering details GHG 981 250 A - 700 A

Rated current	Poles	Enclosure material	Cable entry (metal thread)	Cable glands (plastic)	Enclosure sizes: GRP				Enclosure sizes: metall				Order No. ¹⁾
					Size 1	Size 2	Size 3	Size 4	Size 1	Size 2	Size 3	Size 4	
GHG 981 (250 A)													
250 A	3 pole	316L stainless steel	2xM63, 1xM25									X	GHG 981 0048 R1267
250 A	4 pole	316L stainless steel	2xM63, 1xM25									X	GHG 981 0048 R1268
250 A	6 pole	316L stainless steel	4xM63, 1xM25									X	GHG 981 0048 R1269
GHG 981 (400 A)													
400 A	3 pole	316L stainless steel	2xM63, 1xM25									X	GHG 981 0048 R1277
400 A	4 pole	316L stainless steel	2xM63, 1xM25									X	GHG 981 0048 R1278
400 A	6 pole	316L stainless steel	4xM63, 1xM25									X	GHG 981 0048 R1279
GHG 981 (500 A)													
500 A	3 pole	316L stainless steel	4xM80, 1xM25									X	GHG 981 0048 R1287
500 A	4 pole	316L stainless steel	4xM80, 1xM25									X	GHG 981 0048 R1288
GHG 981 (630 A)													
630 A	3 pole		4xM80, 1xM25									X	GHG 981 0048 R0287
630 A	4 pole		4xM80, 1xM25									X	GHG 981 0048 R0288
GHG 981 (700 A)													
700 A	3 pole		4xM80, 1xM25									X	GHG 981 0048 R0297
700 A	4 pole		4xM80, 1xM25									X	GHG 981 0048 R0298

¹⁾ For an emergency stop switch (red handle/yellow back plate), change the 3rd to last digit from R*2** (standard version) to R*3** (emergency stop)

Accessories

Type	Version	
Cable glands		
Plastic cable glands	M20 up to M63	see: Main catalogue part 2
Metal cable glands	ADE 1 F2	see: Main catalogue part 2

Eaton's Crouse-Hinds series Authorized distributor - Kunshan beiyuan electric co., ltd. / csr@ksbyel.com

Dimension drawing

Size 1 GRP enclosure

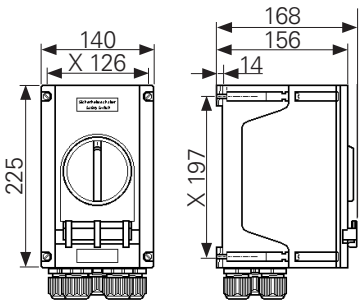

Size 1 stainless steel enclosure

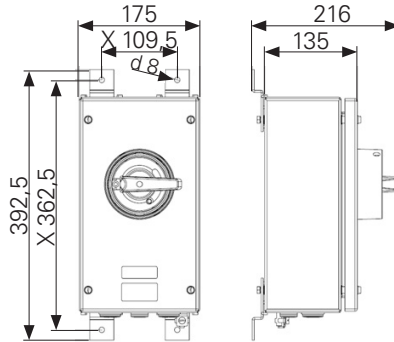

Size 2 GRP enclosure

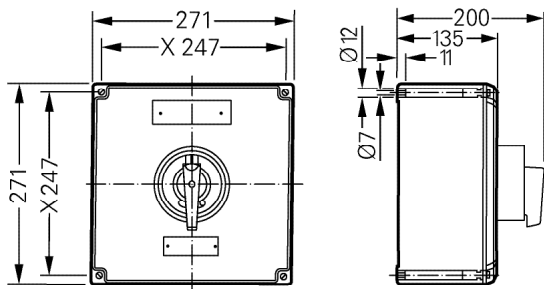

Size 2 stainless steel enclosure

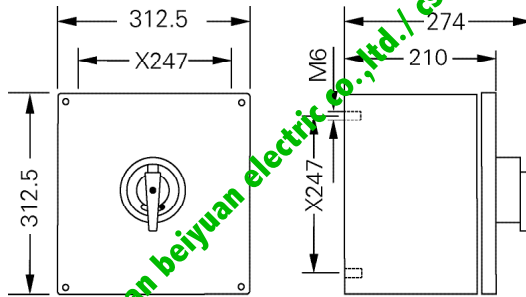

Size 3 GRP enclosure

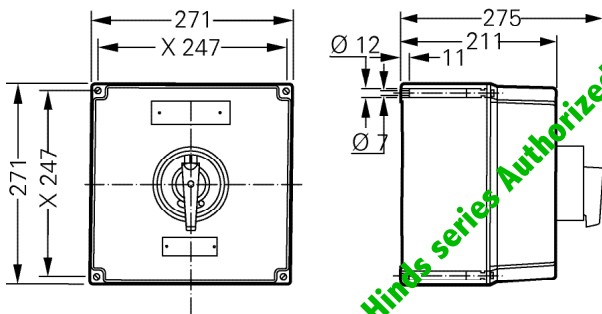

Size 3 stainless steel enclosure

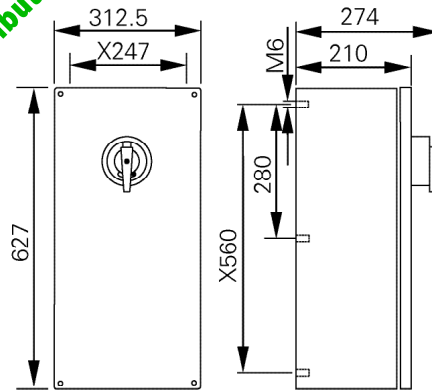

Size 4 GRP enclosure

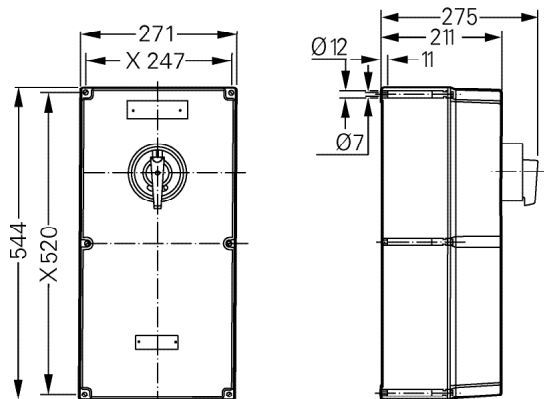

Size 4 stainless steel enclosure

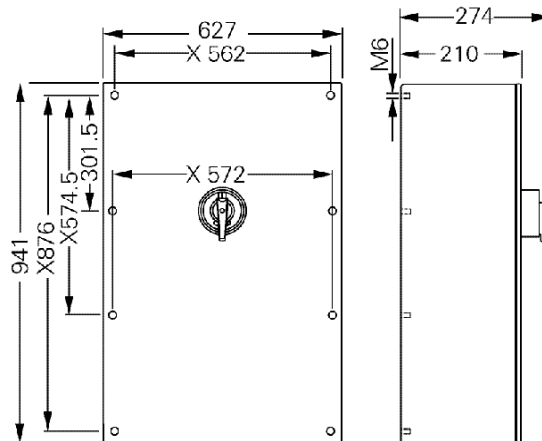

Eaton's Crouse-Hinds series Authorized distributor - Kunshan beiyuan electric co., Ltd. / cst@ksbyel.com