

Twilight switch with Ex-e enclosure



EXKO 231 402 L...

Technical data

Twilight switch with Ex-e enclosure

Marking accd. to 2014/34/EU	Ⓔ II 2 G Ex Ex db eb IIC T5 Gb
EC-Type Examination Certificate terminal box	GHG 721: BVS 13 ATEX E 013 X GHG 74: BVS 12 ATEX E 118 X
EC-Type Examination Certificate twilight switch	PTB 06 ATEX 1017 X
Permissible ambient temperature	-40°C to +55°C
IECEX Certificate of Conformity terminal box	GHG 721: IECEX BVS 13.0031X GHG 74: IECEX BVS 12.0071X
Marking accd. to IECEx	Ex db eb IIC T5 Gb
Rated voltage	105 - 305 V 50/60 Hz
Rated current	max. 10 A
Protection class	I
Rated switching capacity	1800 VA
Light sensitivity	4 - 11 lux, 7 - 12 lux, 10 - 15 lux, adjustable, lower value "ON", upper value "OFF"
Degree of protection accd. to EN 60529	IP66
Enclosure material	glass-fibre reinforced polyester (GHG 721 00) or stainless steel (GHG 744 21)
Enclosure colour	black or polished

Ordering details twilight switch with Ex-e enclosure

Type of enclosure	Enclosure Material	Cable entry	Type of gland	Terminals	Order No.
GHG 721 00	GRP	direct	2 x M20 threaded plug	6 x UT2.5 + 4 x UT2.5 PE	EXKO 231 402 L1121
GHG 721 00	GRP	direct	2 x M20 threaded plug	3 x UT4 + 2 x UT4 PE	EXKO 231 402 L1122
GHG 721 00	GRP	direct	1 x M25 cable gland	3 x UT4 + 2 x UT4 PE	EXKO 231 402 L1131
GHG 721 00	GRP	internal earth plate	1 x M20 threaded plug	3 x UT4 + 2 x UT4 PE	EXKO 231 402 L1212
GHG 721 00	GRP	internal earth plate +PE	1 x M20 threaded plug	4 x WDU2,5 + 2 x WPE4 + 1 x WPE10	EXKO 231 400 L3212
GHG 744 21	Stainless steel	flange	1 x M20 threaded plug + 1 x M20 breathing-/ draining plug	3 x UT4 + 2 x UT4 PE	EXKO 231 405 L1322

Other versions available on request



EXKO 231 402 L 1122

Dimension drawing I wiring diagram

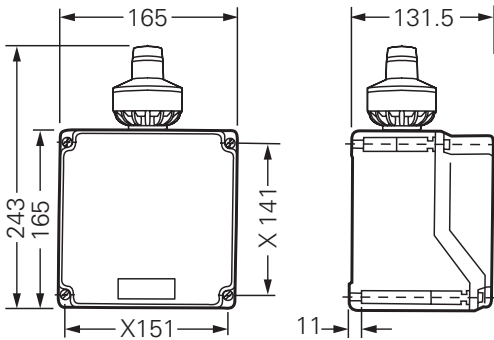

GHG 721 00

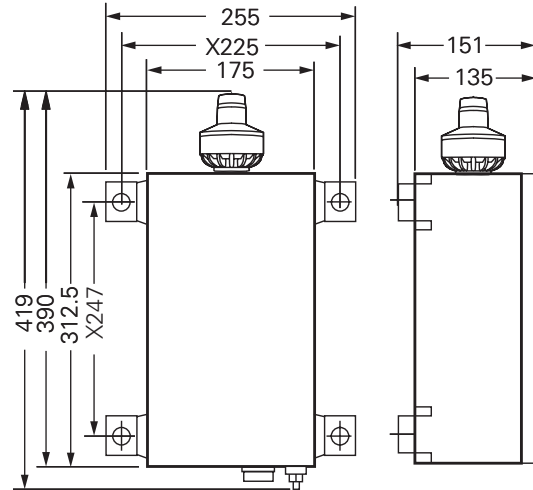

GHG 744 21

Connection diagram for 220/127 V network

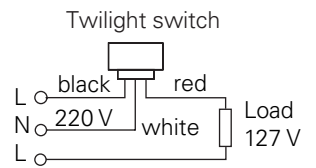
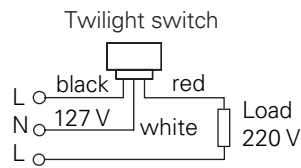
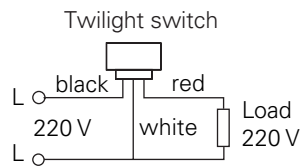
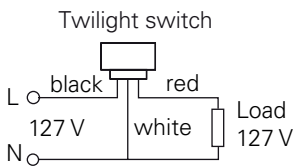

Connection diagram for 400/230 V network

